

TM-RAPTOR-40

OPERATION AND MAINTENANCE OF SOUND SUPPRESSOR MODEL RAPTOR-40

**Before using this suppressor,
be certain you have read and
understand this manual.**

Manufactured by

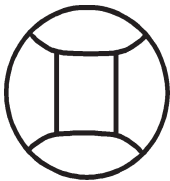

GEMTECH
Div. of Gemini Technologies, Inc.
P.O. Box 140618
Boise, Idaho 83714

ISSUED: February 15, 2008

★ ★ ★ ★ ★ **WARNING** ★ ★ ★ ★ ★

☞ **Because sound suppressed weapons make less noise than non-suppressed weapons, it is easy to forget that they are still firearms. It is of vital importance to remember that a sound suppressed firearm is just as dangerous as a non-suppressed one, and the same safe handling requirements apply.**

TM-Raptor

FIRST EDITION January 1996

SECOND EDITION October, 1996

THIRD EDITION July 2001

FOURTH EDITION July 2003

FIFTH EDITION January 2006

SIXTH EDITION (40) February 2008

Published by:

ATI Star Press

Antares Technologies, Inc.

P.O. Box 140618

Boise, Idaho 83714

Phone: (208) 939-7222

COPYRIGHT NOTICE:

©2008 Gemini Technologies, Inc.

All rights reserved. The contents of this publication may not be reproduced in any form or by any means in whole or in part without the prior written permission of the copyright owner.

TM-RAPTOR

OPERATIONAL MANUAL FOR
SOUND SUPPRESSOR MODEL
RAPTOR-40 (.40S&W and 10mm)

Manufactured by

GEMTECH

Division of Gemini Technologies, Inc.

P.O. Box 140618
Boise, Idaho 83714-0618

Phone: (208) 939-7222

FAX: (208) 939-7804

GEMTECH PROPRIETARY

This document contains proprietary information of Gemtech and is submitted to the receiver in confidence. Any reproduction, use and/or disclosure of this and/or any portion thereof is expressly prohibited without the express written permission of Gemtech

CONTENTS:

General Description	P. 2
Basic Principles	P. 3
Construction	P. 3
Mounting on HK MP5 and MP5K-PDW	P. 3 & 4
Ammunition Notes	P. 5
Routine Cleaning	P. 6
Service of the 3-lug mount	P. 6 & 7
Physical Specifications	P. 8
Warranty and Repair Policy	P. 9

☆☆☆☆☆ **WARNING** ☆☆☆☆☆

☞ **Failure to follow installation and maintenance instructions detailed in this manual can result in potential for serious injury to the user and damage to the weapon.** Firearm sound suppressors are user attached firearm muzzle devices, and as such are subject to improper attachment unless the proper procedures outlined in this manual are followed.

MANUFACTURER'S DISCLAIMER

The manufacturer is not responsible for improper usage of this product. This product is potentially dangerous, and as such it is the user's responsibility to understand and implement its proper use. If you do not understand the instructions in this manual, please contact the manufacturer for further clarification.

Congratulations! You have just obtained a highly efficient, state of the art, versatile, and carefully designed 10mm/.40S&W muzzle suppressor designed for the Heckler & Koch MP5 submachine gun available anywhere. Before use, please take a few moments to read this instruction manual.

GENERAL DESCRIPTION

The RAPTOR-40 suppressor is the most efficient suppressor ever designed for the Hewckler & Koch MP5-40 submachine gun. Designed for high efficiency and rugged abuse, it is configured for mounting on the 3-lug barrel of the H&K MP5 submachine gun utilizing the integral quick detach Gemtech Tri-Lock™ (patented) mount. It is specific to the MP5 in both .40S&W and 10mm. Because the MP5-40 has a threaded barrel, the enclosed smooth thread protector must be used.

With simple maintenance, the RAPTOR-40 suppressor's life-span is in excess of 175,000 rounds (documented). It is specifically designed for fully automatic fire.

Suppression efficiency is gained through proper design of the suppressor rather than by using "wipes," grease, or other obstacles touching the bullet in free flight. For this reason, weapon accuracy is not impaired, and accuracy may be actually slightly enhanced by tightening of the group size.

BASIC SUPPRESSION PRINCIPLES

The sound of a firearm discharging is due to the sudden release of high pressure propelling gases. The purpose of a suppressor is to reduce the gas pressure by a combination of increasing the volume for gas expansion, decreasing gas temperatures, and delaying gas exit from the suppressor.

CONSTRUCTION

The entire suppressor is constructed from anodized aircraft grade aluminum alloys with the exception of steel portions of the Tri-Lock™ mount. Because the radial orientation of the baffles is critical to optimum performance, the suppressor is sealed and cannot be disassembled other than removal of the rear mount. Operational life-span is in excess of 150,000 rounds.

☆☆☆☆ **DANGER** ☆☆☆☆



Before performing any installation or maintenance operation, always remove the magazine from the firearm, open the action, and visually ascertain that the chamber is empty and the weapon unloaded. Failure to do so can result in potential for serious injury to the user and others in the vicinity.

MOUNTING ON HK WEAPONS

The HK MP5-40 submachine gun has muzzle threads. Because of the Tri-Lock mounting system, it is mandatory that the enclosed thread protector be utilized. Additional thread protectors are available if necessary.

When initially installing the thread protector, the threads on both the weapon and protector should be degreased with acetone, alcohol, or MEK. After placing a drop of “Blue” Loctite (#242) on the threads, the thread protector needs to be tightened as much as possible by hand.

We guarantee alignment of the RAPTOR-40 suppressor only on original German 3-lug H&K MP5 barrels with the Gemtech thread protector and those manufactured to German Heckler & Koch specifications. Mounting on non-specification barrels or threaded barrels with non-Gemtech thread protectors is done at the operator's risk.

HK MP5 MOUNTING

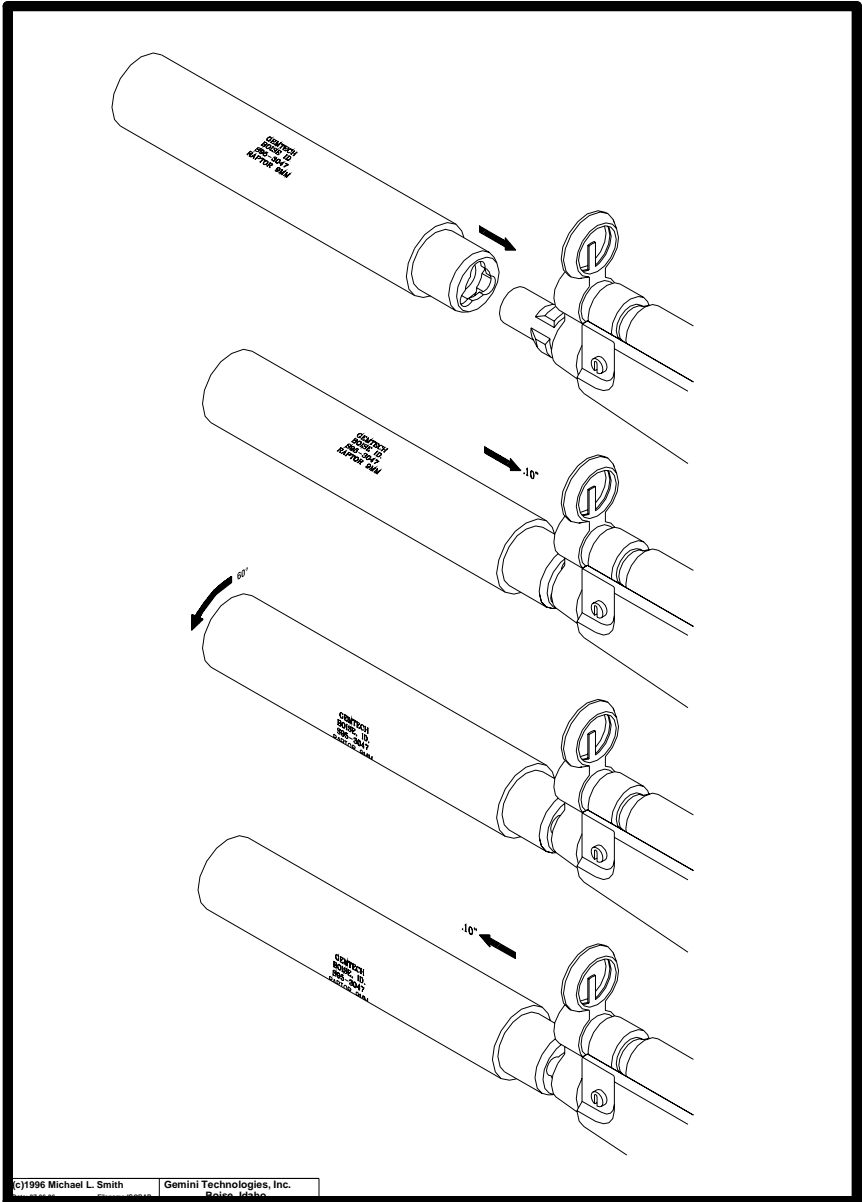

☆☆☆☆☆ CAUTION ☆☆☆☆☆

Before initiating Mount/Dismount Procedures, be absolutely certain that the weapon is unloaded, the magazine removed, and the bolt locked in the rear position.

**RAPTOR-40 3-LUG HK-MP5 MOUNTING INSTRUCTIONS
For the Gemtech TRI-LOCK™ 3-Lug Barrel Coupler**

1. Be certain the weapon is unloaded, the magazine removed, the safety on, and the bolt locked in the open position.
2. Align the grooves in the silencer mount with the lugs on the barrel.
3. Pull the silencer onto the barrel against spring tension until the silencer can be rotated counter clockwise while holding the weapon in the firing position.
4. Rotate the silencer 60° until it stops and release pressure on the silencer. Rock the silencer to be certain that the lugs have engaged the pocket recesses in the mount.
5. Removal is the reverse of installation. It will be necessary to pull the silencer rearward in order to rotate it 60° clockwise.

AMMUNITION NOTES**☆☆☆☆☆ WARNING ☆☆☆☆☆**

Never use ammunition that does not meet SAAMI specifications.

All commercial American made ammunition is safe, but the origins, storage history, and reason for being surplus of foreign made ammunition is not available for evaluation. Although foreign made ammunition is usually safe, this is not always the case. Damage from non-American ammunition cannot be covered under warranty.

Some .40S&S ammunition (and all 10mm ammunition) is supersonic, and the projectile traveling at velocities above approximately 1,050 fps will

produce a ballistic “crack” or “sonic boom”. The user will need to determine by experimentation which ammunition remains subsonic in his weapon.

Using supersonic ammunition is certainly acceptable. While the ballistic crack is present and the dominant sound, the muzzle blast is suppressed to the point that the target cannot determine the origin of the shot.

Reloading (or re-manufacturing) ammunition is popular. The one important consideration is that only jacketed bullets may be used. **Do not use cast lead bullets.** Loading data for subsonic ammunition is available from a number of sources, including the commercial reloading manuals published by powder or bullet manufacturers. *We caution against any attempt to hand load beyond recommended SAAMI specifications.*

We strongly suggest against the use of corrosive ammunition, and evidence of its use will void the warranty. **Never risk your investment in the weapon or suppressor by using cheap ammunition that does not meet SAAMI specifications.**

MAINTENANCE and CLEANING

As a general rule (and contrary to popular opinion), suppressors have a longer life if no attempt is made at cleaning. There are no perfect solvents for the carbon deposited on the internal parts by the burning of the powder, and some carbon residues will slightly enhance performance. Field experience has shown that the suppressor will outlast a number of barrels.

The design of the RAPTOR-40 suppressor is such that any liquid introduced in a cleaning process may not drain completely, and its presence will generate more sludge and residue within the suppressor than not cleaning.

The suppressor is all aluminum, and many normal gun cleaning solvents will damage aluminum. These include Hoppe's, Sweets, GI Bore Cleaner, and all water-based agents. *Water or water-based solvents should never be used.* Because ultrasonic cleaners develop proper cavitation only with water-based solvents and do not function well with organic solvents, we recommend against their usage. Additionally, ultrasonic cleaners can damage aluminum if left in too long. Some water-based carbon removing solvents (such as SLIP-2000) will seriously damage the anodize finish of the suppressor.

What does have merit is to occasionally blow out the suppressor with dry compressed air to blow out loose powder granules. Blowing should be done first from the rear and second from the front.

Any other attempt at cleaning may well shorten the life of the suppressor. If it becomes necessary, the suppressor internals can be rebuilt to factory new condition at a reasonable cost.

SERVICING THE 3-LUG MOUNT

The Raptor-40 3-lug mount can be easily disassembled for servicing. See drawing next page.

1. Unscrew the knurled cap from the body.
2. Remove the spring-loaded piston from the mount body. Remove the spring.

Service consists of:

1. Replace the O-rings if necessary. The O-ring in the body can be removed with a dental pick. O-rings are Viton (neoprene must not be used).
2. Thoroughly clean the spring-loaded piston inside and out. Made of stainless steel, it can be cleaned with red Scotchbrite or fine steel wool moistened with WD-40.
3. Scrub the inside of the knurled cap with a toothbrush and solvent, such as WD-40 or Kroil, to remove all powder and carbon residues. Be certain to clean the recesses that engage the barrel lugs.
4. Coat the outside of the piston with grease as well as the inside of the knurled cap. Lightly coat the inside of the mount body. Suitable greases include marine bearing grease, available at stores that sell boat trailers.
5. Insert the spring in the mount body followed by the piston (small end first). Replace the cap and screw hand tight. Do not use thread adhesives.

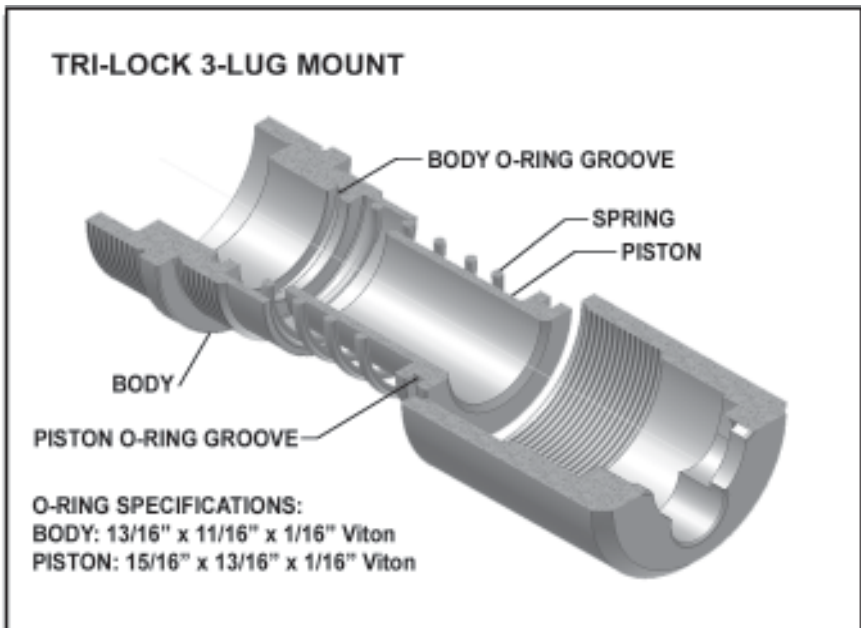

It is not unusual for a small amount of grease to be forced through the small vent hole in the knurled cap. This hole is to prevent pressurization of the mount.

PHYSICAL SPECIFICATIONS

Length	8.2 inches
Diameter	1-3/8 inch
Weight	8.5 ounce
Suppression*	30 dB(A) dry
Operational life	150,000 rounds minimum

*NOTE: Suppression will vary slightly with ammunition used. We recommend against the use of water or other artificial environment media in the suppressor.

THREAD PROTECTOR SPECIFICATIONS

Length	0.652 inches
Diameter	0.645 inch
Thread	M14x.75-RH

WARRANTY STATEMENT

Our "warranty" has been practiced since our personnel started in the suppressor business in 1976, in a time before legalese and when a handshake and this simple statement sufficed: "If a Gemtech product breaks and it's your fault, we'll fix it for a fair price in a timely manner. If it's our fault, we'll fix it quickly at no charge." This policy born of pride in craftsmanship and honor has served us and our clients well for over two decades and will continue in Gemtech's future.

The small print follows:

The Magnuson-Moss Act (Public Law 93-637) does not require any seller or manufacturer of a consumer product to give a written warranty. It does provide that if a written warranty is given, it must be designated as "full" or as "limited" and sets minimum standards for a "full" warranty.

As do all major firearms manufacturers, Gemtech has elected not to provide any written warranty, either "limited" or "full," rather than to attempt to comply with the provisions of the Magnuson-Moss Act and the regulations issued thereunder.

There are certain implied warranties under state law with respect to sales of consumer goods. As the extent and interpretation of these implied warranties varies from state to state, you should refer to your state statutes.

Gemtech certifies that all sound suppressors manufactured by them are free of defects in materials or workmanship, and that they meet manufacturing specifications at the time of manufacture.

It is our intent that the customer be completely satisfied with the product. Certain Gemtech products may be classified as ordnance and/or implements of war and are sold by us with the specific understanding that Gemtech has taken every reasonable precaution in providing our customers with inherently safe merchandise, and that we assume no liability whatsoever for unsafe handling by the purchaser or his agents. Gemtech assumes no responsibility whatsoever and we will honor no claims for damages, regardless of nature, for physical injury or property damage resulting from careless and/or irresponsible handling, adjustments to equipment, neglect or abuse.

Gemtech reserves the right to make changes at any time and without notice, in prices, to change specification or design, to add or remove accessory materials, and to add or delete items without incurring any obligation.

Use of ammunition that does not meet SAAMI specifications will void all warranties.

REPAIR POLICY

Gemtech maintains complete repair facilities for all suppressors manufactured by them or their antecedent companies. Return authorization and shipping instructions must be obtained prior to return. Contact Gemtech for this information.

ATF no longer requires transfer on a Form 5 to the manufacturer for repair. However, they do require a letter accompanying the weapon detailing the repairs required. We will require also a photocopy of the front of the owner's Form 3, 4, or 5.

GEMTECH
Serving the industry for 15 years

All Gemtech products are
100% manufactured in the
United States of America.

